



Best Way's book of

ETHOS

A Book of Moral Values

ANSWER KEY

3

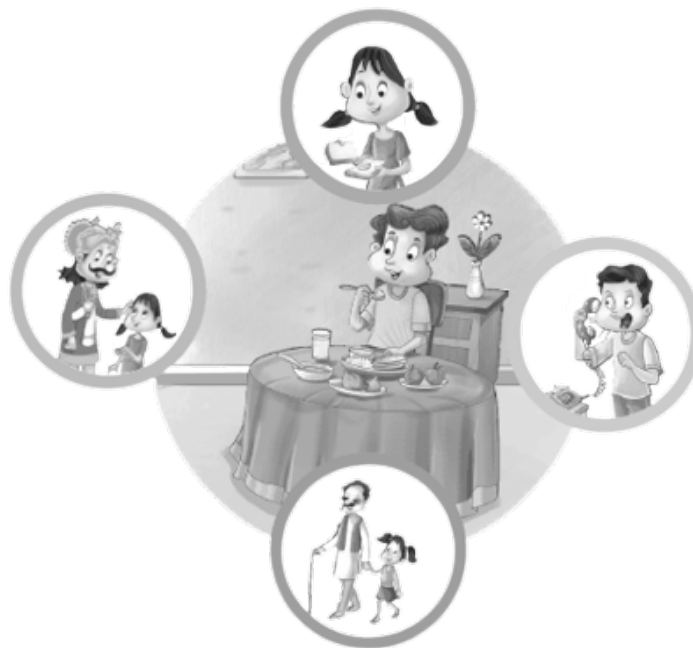

Best Way Publications Pvt. Ltd.

A-1/50 B, Keshav Puram, New Delhi-110035

Phone: +91-9350505657, 011-47073550

E-mail: Info@bestwaypublications.com / Web: www.bestwaypublications.com

1

Being Brave

Knock Around!!

- A. Think about the things you are afraid of. Make a list of those things and write in the given space. Also, write what can you do to overcome your fear from these things. You can take help from your teacher and parents:**

Ans: (i) I am afraid of sleeping alone - I will try to sleep alone and gradually. Will overcome my fear.

(ii) I am afraid of going out to new places. To overcome this I will take help from my parents and will try to explore more new place.

- B. Search on internet about the Bravery Award and design this award on your own. Gather information about the same. Also, write to whom you want to give this award in your class:**

Ans: Bravery Award are a set of awards given to children below 18 years for their acts of bravery against all odds. In my class I will give this award to Rita.

- A. Tick (✓) the correct option?**

1. What did the cockerel and the duck want to see?

Ans: Mermaids

2. Where did they go to search the mermaids?

Ans: Under the sea

3. They go so deep that they were in complete _____.

Ans: darkness

4. The mermaids were very _____.

Ans: happy

5. The cockerel and the duck became great _ with the mermaids.

Ans: friends

- B. Write T for true and F for false statements:**

1. Brave people have a strong mind. **T**

2. Being fearless means one should play with fire. **F**

3. Most of our fears are due to our false imaginations. **T**

4. Getting off a moving bus is an act of bravery. **F**

- C. Make a sentence using the given words:**

1. **Argue:** We should no argue with others.

2. **Bottom:** She sank to the bottom of the swimming pool

3. **Dived:** The fish flipped and dived back into the water.

4. **Encourage:** We should encourage each other with kind words

5. **Scared:** The rabbit in the garden looked scared.

6. **Brave:** Brave people have a strong mind.

- D. If you were at the place of cockerel, then what would you do? Would you do the same as the cockerel did or refuse to go back inside the depth of the sea again?**

Ans: I would have done the same as the cockerel. I would have gone back inside the depth of the sea again.

- E. Answer the following questions:**

1. Why were the cockerel and the duck arguing?

Ans: Whether mermaids exists or not cockerel and the duck arguing

2. Why did they return to the surface?

Ans: Darkness made them scared.

3. What did the duck do to fight against the fear of the cockerel?

Ans: Duck took the torch duck do to fight against the fear of the cockerel.

4. What did they see deep inside the sea?

Ans: Mermaids

5. How did the mermaids respond to see the cockerel and the duck back into sea again?

Ans: Mermaids were happy and thanked their bravery and perseverance.

Homework

1. What do the brave people do?
Ans: Stand up for others
2. Sana raises her hand to participate in a dance programme? Is she brave?
Ans: Yes
3. Hitesh watched someone is bullied and doesn't tell anyone. Is he brave?
Ans: No

2

Being Honest

Tune-UP

An honest individual always tells the truth. Draw one way you can show to others that you are an HONEST individual?

Ans: Do it yourself

Knock Around!!

A. Take out the words from the box and decide if the word describes honesty or dishonesty. Then, write them in appropriate column:

Corrupt, True, Thief, Cheat, Reliable, Genuine, Liar, Responsible, Sneaky, Can't be trusted, Trustworthy, Unfair

Honest	Dishonest
true	corrupt
reliable	theif
genuine	Cheat
responsible	liar
trustworthy	can't be trusted
	unfair
	sneaky

B. Make an honesty tree, in which you have to write the qualities of an honest person:



A. Tick (✓) the correct option?

1. Paul always spoke:
Ans: truth
2. The king was giving away cookies and___?
Ans: candies
3. What did Paul notice among the candies?
Ans: Ring
4. What did the king offer to Paul??
Ans: Gold Coins
5. Did the boy and his family become rich?
Ans: Yes

B. Write the opposite for each of the following words:

1. **Honest** - dishonest
2. **Poor** - Rich
3. **Truth** - Lie
4. **Near** - Far
5. **Beautiful** - Ugly
6. **Happy** - Sad

B. Write T for true and F for false statements:

1. Paul was a good boy and always spoke truth. **T**
2. All the villagers came out to fight with the king. **F**

3. The king was giving away cookies and candies. **T**
4. The king got to Paul and gave him an empty box. **F**
5. Paul noticed that there was a beautiful ring among the candies. **T**
6. Paul kept the beautiful ring of the king with him. **F**

D. Define the phrase "Honesty is the best policy" in your own words:

Ans: Honesty is the best policy means that telling the truth is better than lying even when it is hard to do.

E. Answer the following questions:

1. Where did the poor boy live and how was he?
Ans: Poor boy lived with his family he was good boy and always spoke truth.
2. What did the king distribute to the villagers?
Ans: Cookies and candies
3. What did Paul get along with candies?
Ans: A beautiful ring.
4. How did Paul show his honesty?
Ans: He returned the ring to the king.
5. What happened at the end of the story?
Ans: The king appreciated Paul's honesty and his family became rich.

Homework

A. Write five quotes on honesty and explain each:

Ans: (i) **Honesty is the best policy** - Honesty proves itself to be the right solution when dealing with your fellow human beings.

(ii) **Honesty is the fastest way to prevent a mistake from turning into failure** - We should be honest by being honest we can prevent our mistakes from turning into failure.

(iii) **If you want to be trusted, be honest** - People only trust those who are honest.

B. Make a tree stepwise (like Christmas tree) and start writing down that in a day how many times did you lie. Do this activity for a week and at the end of the week, observe it how much honest you are:

Ans: Do it yourself.

My Learnings

What have you learnt from this story?

Ans: Honesty is the best policy. We should be honest in every situation.

3 Self Awareness is Important

Tune- UP

Fill this:

1. I am strong in these areas:
Ans: Playing football, studying
2. I struggle with:
Ans: basketball
3. My favourite thing about school is:
Ans: studying with my classmates.

Knock Around !!

A. Check your awareness and fill the following boxes. What is your thinking about the following:

My family: I love my Family	My Friends: Richa	Favourite Music/Movie: Taara zameen par	Favourite Colour: Red
Worst Memory: A bad dream	Best Memory: Winning a Competition	Favourite food: I loved to eat rice	Favourite Book: Ethos
Best subject: Moral Science Worst subject: Social	Favourite food in school canteen: Samosa	Favourite port: pending	Favourite clothes: Red shirt

B. In the given box, draw a self portrait:

Ans: Do it yourself.

A. Tick (✓) the correct option?

1. What was the rumor that his neighbour spread about the young man?

Ans: Thief

2. Later the young man was proven _____ .

Ans: innocent

3. Did the old man complete the task given by judge?

Ans: No

4. The old man realised his mistake and asked for :

Ans: forgiveness

B. Write T for true and F for false statements:

1. The young man was proven innocent. **T**

2. He sued the old man for wrongly accusing him. **T**

3. The judge made the old man realise his mistake. **T**

4. The old man did not accept his mistake. **F**

5. The judge asked the old man to collect the papers that he threw yesterday. **T**

C. Write the moral of the story in your own words:

Ans: Self awareness helps you believe that you are capable in doing and achieving great and protect you from unfair means.

D. Write the meaning of the following words:

1. **Rumor** - praise

2. **Innocent** - guilty

3. **Accuse** - absolve

4. **Destroy** - build

5. **Forgive** - blame

6. **Mistake** - be right

E. Answer the following questions:

1. What was the rumor spread by the old man?

Ans: His neighbour was a thief.

2. What did the young man do after he released?

Ans: He see the old man.

3. What did the judge tell the old man to do:

Ans: To collect pieces of paner that he threw yesterday.

4. Did the old man realise his mistake? What did he say?

Ans: res, the old man realise his mistake and asked for forgiveness.

Homework

We all have feelings. We show our feeling with emotions on our face, by smiling when we re happy or frowning when we are sad. Look at the words below and write them in one of the boxes, drawing the emotion on the blank face:

Sad Happy Scared Angry



Scared



Happy



Sad



Angry

4

Punctuality is... Necessary

Tune-UP

Note the actual time and time when you do the following:

		Actual	Done
1.	School time	7:45am	7:40am
2.	Luch time	3:00pm	2:50pm
3.	Playing time	6:00pm	6:15pm
4.	Studying time	7:00pm	7:30pm
5.	Sleeping time	10:00pm	10:15pm

Knock Around!!

A. Make your own time-table for doing the work that you have to perform in a day. Now, make a chart and note that how much you are following your time-table and how much you are lacking it. Make a habit of being puctual:

Ans: Do it yourself.

B. How do you feel when you reach to a railway station and you find that your train is late for two hours? Write your feelings in the given lines:

Ans: I feel sad because now I have to wait but satisfied too that I reached on time.

A. Tick (✓) the correct option?

1. A wolf and _____ were two friends in a forest.

Ans: Fox

2. A wolf and a fox were invited for a _____.

Ans: dinner

3. Who was dreaming, "What a nice food I am going to have"?

Ans: Wolf

4. Did the fox go away leaving the wolf behind?

Ans: Yes

5. The fox was _____ for the wolf to come.

Ans: waiting

B. Who said this:

1. My dear friend we need not to go in a hurry. **Wolf**
2. We must behave like good guests. **Fox**
3. I want to rest for some time. **Wolf**
4. You have to go back without food. **Fox**
5. I will not be late again here after. **Wolf**

C. Write the moral of the story in your own words:

Ans: Time once gone is gone forever. We should not be late.

B. Write T for true and F for false statements:

1. A wolf and a fox were enemies. **F**
2. Wolf fell asleep on the way. **T**
3. Fox wanted to reach on time and behave like a good guest. **T**
4. The wolf ate a variety of food. **F**
5. The wolf felt sad. **T**

E. Answer the following questions:

1. Who were friends?
Ans: Fox and Wolf.
2. Why did the fox rush early for the dinner?
Ans: Fox wanted to behave like a good guest.
3. What did the wolf want to do?
Ans: Wanted to rest..
4. What was the wolf dreaming for?
Ans: Delicious food.
5. Did the fox enjoy the dinner and why?
Ans: Yes fox enjoy and dinner because she reached on time.
6. Did the wolf reach on time in the party? What happened when he reached there?
Ans: No the wolf didn't reach on time in the party the dinner was over everyone had left.

Homework

I show punctuality when I wake up in the morning for school.

1. **Complete the sentence above.**
2. **In the given lines, write a definition of punctuality:**
Punctuality refers to the quality of being on time.
3. **Write details about the things you will do to plan your life so that you will show punctuality everyday:**

I will set my alarm on time, so that I will get up on time and will not be late for the school.

My Learnings

What have you learn from this story?

Ans: We should be punctual in life. If we are not punctual, we might miss many important things in life.

5 Give Respect, Take Respect

Tune-UP

What will you do in the following situations?

1. You want to have an ice cream but your Friend wants to have chocolate.
Ans: I will let my friend buy chocolate we can have ice cream some other day.
2. You want to go to the market but your father is tired.
Ans: I will ask my father to rest. We can go some other day.
3. Your mother is doing some work and you want to spend time with her.
Ans: I will help my mother in finishing the work early so I can spend time with her.

Knock Around!!

A. Explain the given proverb in your own words. What do you understand by this?

"Treat people the way you want to be treated".

Ans: If you want people to treat you with respect, then you should treat them with respect too.

B. Make a banner on respect. You can make it from cardboard, waste material, wallpaper or construction paper. Decorate your banner with pictures and word cutouts that show respect. Include at least 10 ways to show respect to others.

Ans: Do it yourself.

A. Tick (✓) the correct option?

1. The wolf was making _____ of the moon.

Ans: fun

2. Who was consoling the moon?

Ans: Hedgehog

3. Both the animals were _____ ?

Ans: lost

4. Who helped the hedgehog when he lost in the forest?

Ans: Moon

5. Who was ashamed for his bad attitude ?

Ans: Wolf

B. Write the meaning of the following words:

1. **Howling** - wailing sound

2. **Console** - Comfort

3. **Storm** - disturbance of atmosphere

4. **Frightened** - afraid

5. **Rudeness** - lack of manners

6. **Cruel** - barbarous to grant

7. **Attitude** - feeling about something

8. **Forgive** - to grant pardon

C. Write few lines on the moral 'Respect':

Ans: (i) Respect means that you accept somebody for who they are even when they are different from you or you don't agree with them.

(ii) Respect doesn't have to come naturally it is something you learn.

D. How would you feel if you were at the place of moon?

Ans: I would have felt sad by the words of wolf.

E. Answer the following questions:

1. What happened when the wolf and the hedgehog were far from home?

Ans: They were caught in the storm.

2. How did the moon help the hedgehog?

Ans: By gathering all her light in a single ray showing the way to hedgehog the moon helped the hedgehog.

3. What did the wolf realise?

Ans: The wolf realised that all his rudeness to the moon had been pointless and cruel.

4. Did the Moon help the wolf?

Ans: Yes, after the wolf asked for forgiveness.

Homework

Respect our country's National Flag. Colour the picture of given flag and write some respectful lines for it:

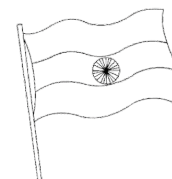

Ans: (i) The national flag of India upholds its people's honour and independence from British rule.

(ii) It is referred to as the 'Tiranga' or tricolour parallel bands - saffron, white and green.

(iii) These colours represent India's freedom, unity, strength and symbol.

6

Forgive and Forget

Tune-UP

What will you do if you find that your favourite toy is broken by your younger brother? Will you forgive him or punish him for this?

Ans: I will forgive him for his mistake.

Knock Around !!

Think that who will call the great - 'That forger or the person who realise his/her mistake and asking for apology for the same'. Write your views here under:

Ans: The forgive the person asking for apology both are great at their places. Forgiving someone for their mistake requires courage similarly it is not easy for a person to realise his mistake and apologise for it.

A. Tick (✓) the correct option?

1. Tim had nice:

Ans: hair

2. Who loved his haircut?

Ans: Tim

3. What did Tim try to give Sam?

Ans: Hug

4. Mother asked Tim to _____ Sam.

Ans: forgive

5. Did Tim forgive Sam?

Ans: Yes

B. Write T for true and F false statements:

1. Tim was very naughty boy. **F**

2. Sam wasn't nice to Tim. **T**

3. Sam haircut was great and he loved it. **F**

4. Tim slapped Sam. **F**

5. Mother told Tim that he should forgive Sam. **T**

6. Tim and Sam became great friends again. **T**

C. Write the moral of the story in your own words:

Ans: Forgiveness is not a feeling, it is a decision - a choice we have to make.

D. Answer the following questions:

1. Where did the two friends go?

Ans: The two friends go to get a haircut together.

2. Why was Sam upset and what he did in his sad mood?

Ans: Sam upset was because he didn't like his hair in his sad mood he hit on the face.

3. How did Tim try to calm down Sam?

Ans: Tim try to calm down Sam? By giving him a hug

4. What lesson was given to Tim by his mother?

Ans: The lesson which given to Tim by his mother. That tim should for give Sam.

5. What happened at the end of the story?

Ans: Sain said sorry to Tim and they became great friends again.

Home Work

A. Frame your own story on forgiveness. Write your personal experiences and take help from your parents:

Ans: Once my firend lia and I got into a argument. we said foul words to each other. and despite being in the same class we didn't speak for days until my teacher noticed us then she explained on the value of forgiveness we recognised her meaning, asked for forgiveness from on another and became friends again.

B. Find the Hidden Message:

Direction: Using the gameboard given below, cross out every third letter to reveal a hidden message. Then, fill the letters in the answer box.

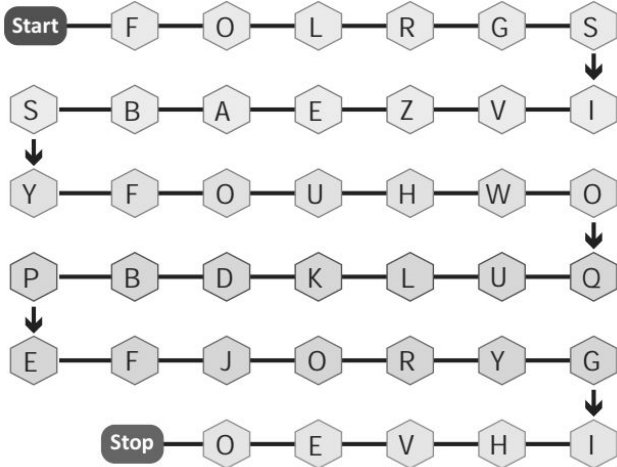

Ans: F O R G I V E

7

One Team, One Dream

Tune-UP

Tick (✓) the correct option?

1. What is teamwork?

Ans: Working together with other people to achieve goal.

2. What are some better ways to show teamwork?

Ans: To cooperate and get along with others in your team.

Knock Around !!

Suppose team India won the match. To whom will you give the credit for their winning and why?

Ans: The credit for winning goes to the whole team because when there is teamwork and collaboration wonderful things can be achieved.

A. Tick (✓) the correct option?

1. The greatest treasure in the world was hidden in a:

Ans: (a) chest

2. The chest was locked and was inside the:

Ans: (a) cave

3. What did the monkey find?

Ans: (a) Key

4. Who realised that the animals should work together?

Ans: (a) Owl

5. What was inside the chest?

Ans: (a) Parchment

B. Have you ever participated in any competition as a team member? If yes, write your experience in the given space:

Ans: Yes, I have participated in a drawing competition as a team member. Together we worked really hard to achieve our goal. I was so happy to work together.

C. Write the meaning of the following words:

1. **Treasure** - Valuable thing

2. **Chest** - Large box

3. **Cave** - an underground chamber

4. **Boulder** - large rock

5. **Success** - accomplishment of an aim

6. **Parchment** - Prepared as writing material

D. Make a sentence using the given words:

1. **Treasure** - The house was large and full of art treasures.

2. **Hidden** - That old temple is hidden among trees.

3. **Snake** - Raghav is terrified of being bitten by a snake.

4. **Together** - In school, all the students studies together.

5. **Adventure** - We want to go on a family adventure vacation.

E. Answer the following questions:

1. Where was the greatest treasure hidden?

Ans: The greatest treasure was hidden in a chest.

2. Who all tried to find the chest on their own?

Ans: Snake, monkey and elephant

3. What did the owl suggest to do?

Ans: The owl suggest to work together as a team.

4. What was inside the chest and what did it say?

Ans: There was a parchment inside the chest and it said that they have found the greatest treasure that of friendship.

Homework

A. In the given box, draw a beautiful drawing that shows the teamwork, Now, your teacher will decide whose drawing and creativity is best:

Ans: Do it yourself

B. Write the importance of teamwork in your own words:

Ans: Teamwork is important because it helps your team to share ideas and responsibilities which reduces stress on everyone and will help in meeting the goals.

8

Love for Nation

Tune-UP

Identify the following freedom fighters and write their names:



Bhagat Singh



Mahatma Gandhi



Netaji Subhash Chandra Bose



Rani Lakshmi Bai

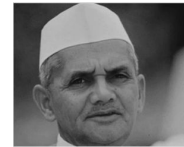

Lal Bahadur Shastri



Lala Lajpat Rai

Knock Around !!

A. Write about the Independence of India. Search on internet or take help from your parents and teachers and gather the information about how India became independent and what were sacrifices the soldiers of our country. Write in the given lines:

Ans: India got Independence on 15 August, 1947 from British rule. It was a hard and long struggle in which many freedom fighters sacrificed their lives. Reach as Bhagat Singh, Rani of Jhans, Subhash Chandra Bose are some notable names.

B. Gather the information about 'The Statue of Unity' and explain its qualities and tell that to whom it is dedicated:

Ans: The State of Unity is the world's tallest statue, located in the state of Gujarat, India. It is dedicated to Sardar Vallabhbhai Patel who was the first deputy Prime Minister and Home minister of India. It is a symbol of unity of India.

A. Tick (✓) the correct option?

1. Subhas Chandra Bose became famous as:

Ans: Netaji

2. When was Netaji born?

Ans: 23rd January 1897

3. Netaji returned to Bharat after clearing exam.

Ans: ICS

4. Did Netaji take exam?

Ans: No

5. Do you love your country?

Ans: Yes

B. Who said this:

1. It is not possible to answer this question.

Ans: Subhash Chandra Bose

2. This question is very important.

Ans: Invigilator

3. You can keep your job!

Ans: Netaji

4. It is better to die instead of showing such helplessness.

Ans: Netaji

C. Write the meaning of the following words.

1. **Brave** - Courageous

2. **Famous** - renowned

3. **Returned** - Come or go back angry

4. **Refuses** - reject

5. **Furious** - angry

6. **Dishonest** - Honest

7. **Dissent** - differ in opinion

8. **Hunger** - Weakness due to lack of food

D. Make the sentence using the given words:

1. **Famous:** Raj was **famous** as both teacher and scientist.

2. **Nation:** The President will speak to the **nation** tonight.

3. **Patriotism:** **Patriotism** is a feeling of love, devotion for on is country.

4. **Soldiers:** **Soldiers** are brove they its from enemies.

5. **Dishonest:** She got punishment for being **dishonest**.

6. **Ingredient:** Two **ingredients** are required for making juice.

7. **Country:** I love my **country** India.

E. Answer the following questions:

1. Who was Subhas Chandra Bose? By which name he got famous?

Ans: Subhash Chandra Bose was a great and brave leader of our contry he got famous by the name of Netaji.

2. When was Subhas Chandra Bose born?

Ans: Subhash Chandra Bose was born on 23 January, 1897.

3. What question was asked in the exam?

Ans: Translation of a Paragraph which read Indian soldiers are generally dishonest.

4. What happened in the examination hall?

Ans: Netaji asked the invigilator to delete the question but he refused.

5. Did Netaji complete the exam? Why?

Ans: No Netaji didn't complete the exam because he was not ready to bear any false allegation againt his country men.

Homework

A. Make a song by yourself, which you want to dedicate to our soldiers:

Ans: In a world full of chair, where battle rage, our soldiers stand tall, on history page with courage and honour, they fight for our land united as one, a courageous band.

B. Who is your favourite leader? To whom do you admire the most and want to become like him/her? Paste the picture of your favourite leader in the given box and write why do you like him/her the most:

Ans:



Lal Bahadur Shastri

Ans: Lal Bhadur Shastri is my favourite leader. He was the 2nd Prime minister of India. He was a great leader who worked for his country selflessly. He also gave the popular slogan "Jai Jawan Jai Kisan".

My Learnings

What have you learnt this story?

Ans: We must love and respect our country and its people.

9

Save the Nature

Tune-UP

Colour "GOOD THINGS" with green and 'BAD THINGS' with red:

Waste paper	tell other about ways to help planet.	leave the computer on	drop litter
recycle gass	tease animal	plant a tree	walk to the school
use lot of water green	use plastic bags	use things again	leave taps on

A. Tick (✓) the correct option?

- Where was the boy playing?
Ans: In a garden
- Who was skipping and jumping?
Ans: Frog
- Who was buzzing over the cow?
Ans: Fly
- Which part of the rose pierced the boys fingers?
Ans: Thorn
- What did the mother say, "It is your"?
Ans: mistake

B. Write T for True and F for False statements:

- The boy was running after butterflies. **T**
- The boy saw a squirrel skipping and jumping. **F**
- The cow was chewing the grass. **T**
- The boy was not enjoying the beauty of nature. **F**

- The boy tried to pluck some of the roses.

T

- Mother was praising the boy for plucking the rose. **F**

C. Write a few lines of 'Environmental Awareness' in your own words:

Ans: (i) A clean enviornment is essential for the peaceful and healty survival of humans

(ii) Human activities negtively affect environment.

(iii) Government and citizens a like should lake steps to our environments

D. What would you do if you were at the place of that boy?

Ans: If I would have been there at the place of that boy would have never tried to pluck a flower. Because Nature is precious and we should not harm it.

E. Answer the following question:

- What was the boy doing in the garden?
Ans: Playing
- What was the cow doing?
Ans: Cow was grazing in the garden.
- Why did the boy start crying?
Ans: A thorn pierced his finger.
- What lesson did the mother teach to her son?
Ans: Natural beauty should never be harmed.
- What did the boy lean from his mistake?
Ans: The boy learned that we should protect all living beings whether animals or plants.

Homework

Look at the picture and write your view for the same:

Ans: (i) This picture is of a school.

(ii) In the school the children are happily planting new planty to make our sourrounding more queen. The teacher is encouraging them to do so.

My Learnings

What have you learnt from this story?

Ans: We should protect all living beings whether it is plant or animals. Unnecessary interference with nature is harmful.

Modal Test Paper-1

A. Tick (✓) the correct option?

1. What did the cockerel and the duck want to see?

Ans: Mermaids

2. What did Paul notice among all the candies?

Ans: Ring

3. What was the rumor that his neighbour spread about the young man?

Ans: Theft

4. The fox was _____ for the wolf to come.

Ans: waiting

B. Write T for true and F for false statements:

1. Brave people have a strong mind.

2. The king was giving away cookies and candies.

3. The old man did not accept his mistake.

4. The wolf ate a variety of food.

C. Write the opposite for each of the following words:

1. **Honest** - dishonest

2. **Poor** - Rich

3. **Truth** - lie

4. **Near** - Far

D. Write the meaning of the following words:

1. **Rumor** - Praise

2. **Destroy** - build

3. **Forgive** - blame

4. **Mistake** - Be right

D. Answer the following questions:

1. Why were the cockerel and the duck arguing?

Ans: Whether mermaids exist or not cockerel and the duck arguing.

2. How did Paul show his honesty?

Ans: He returned the ring to the king.

3. What did the judge tell the old man to do?

Ans: To collect pieces of paper that he threw yesterday.

4. What did the wolf want to do?

Ans: Wanted to rest.

Model Test Paper-2

A. Tick (✓) the correct option?

1. Who was consoling the moon?

Ans: Hedgehog

2. What did Tim try to give Sam?

Ans: Hug

3. What did the monkey find?

Ans: Key

4. Netaji returned to Bharat after clearing exam.

Ans: ICS

B. Write the meaning of the following words:

1. **Storm** - disturbance of atmosphere

2. **Cruel** - barbarous of heart

3. **Cave** - an underground chamber

4. **Boulder** - Large rock skin of Sheep

D. Write a few lines on 'Environmental Awareness' in your own words:

Ans: (i) A clean environment is essential for the peaceful and healthy survival of humans

(ii) Human activities negatively affect environment.

(iii) Government and citizens alike should take steps to our environments.

E. Answer the following questions:

1. What happened when the wolf and the hedgehog were far from home?

Ans: They got wolf and the hedgehog were far from home.

2. What lesson was given to Tim by his mother?

Ans: He should forgive his friend Sam was given to Tim by his mother.

3. What did the owl suggest to do?

Ans: The owl suggest to work together as a team to do?

4. Did Netaji complete the exam? Why?

Ans: No Netaji didn't complete the exam because he was not ready to bear any false allegation against his country men.